

1200V 100A CoolFAST™ IGBT7 Power Module

Electrical Features:

- 1200V 100A, $V_{CE(sat)} = 1.7V@25^{\circ}C$
- High RBSOA Capability
- Trench/FS Technology
- Low Reverse-recovery Losses
- High SC Capability

Applications:

- Motor Drives
- Servo Drives
- Auxiliary Inverters
- Uninterruptible Power Supply



Mechanical Features:

- High Power and Thermal Cycling Capability
- Maximum Junction Temperature $175^{\circ}C$
- High Power Density
- PressFIT Contact Technology
- Isolated Base Plate

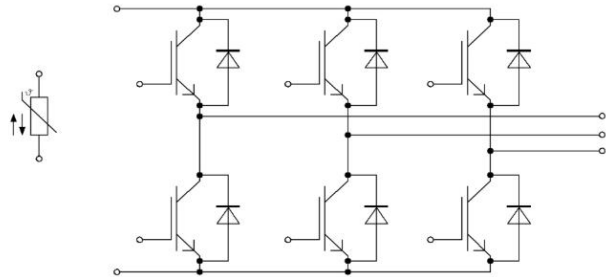

Equivalent circuit

Maximum Ratings and Characteristics

Absolute Maximum Ratings at $T_c = 25^{\circ}C$ (unless otherwise specified)

Items	Symbols	Values	Units	Remarks
Collector-Emitter voltage	V_{CES}	1200	V	
Gate-Emitter voltage	V_{GES}	± 30	V	
DC Collector Current	I_C	100	A	$T_c = 100^{\circ}C$
Repetitive Peak Collector Current	I_{RM}	200	A	$t_p = 1ms$
Diode Forward Current	I_F	100	A	
Repetitive Peak Forward Current	I_{FRM}	200	A	
Operating Junction Temperature	T_{vj}	-40 ~ +150	$^{\circ}C$	
Storage Temperature	T_{stg}	-40 ~ +125	$^{\circ}C$	

Electrical characteristics (unless otherwise specified)
IGBT, Inverter

Description	Symbols	Conditions	Values			Unit	
			Min	Typ	Max		
Zero Gate Voltage Collector Current	I_{CES}	$V_{CE}= 1200V, V_{GE}= 0V$ $T_{vj}= 25^{\circ}C$			200	μA	
Gate-Emitter Leakage Current	I_{GES}	$V_{CE}= 0V, V= 20V, T_{vj}= 25^{\circ}C$			± 300	nA	
Gate-Emitter Threshold Voltage	$V_{GE(th)}$	$V_{CE}= V_{GE}, I_C= 100mA$	5.5	6.1	6.7	V	
Collector-Emitter Saturation Voltage	$V_{CE(sat)}$	$V_{GE}= 15V$ $I_C= 100A$	$T_{vj}= 25^{\circ}C$		1.7	2.2	V
			$T_{vj}= 125^{\circ}C$		2.08		
			$T_{vj}= 150^{\circ}C$		2.23		
Input Capacitance	C_{ies}	$V_{CE}= 25V, V_{GE}= 0V$		21		nF	
Reverse Transfer Capacitance	C_{res}	$f= 1MHz$		0.12		nF	
Gate Charge	Q_G	$V_{CC}= 600V, V_{GE}= 15V$		1.80		μC	
Internal Gate Resistor	R_{Gint}	$T_{vj}= 25^{\circ}C$		3.0		Ω	
Turn-On Delay Time, Inductive load	$t_{d(on)}$		$T_{vj}= 25^{\circ}C$		0.36	μs	
			$T_{vj}= 125^{\circ}C$		0.34		
			$T_{vj}= 150^{\circ}C$		0.33		
Rise Time, Inductive load	t_r		$T_{vj}= 25^{\circ}C$		0.09	μs	
			$T_{vj}= 125^{\circ}C$		0.10		
			$T_{vj}= 150^{\circ}C$		0.11		
Turn-Off Delay Time, Inductive load	$t_{d(off)}$	$V_{CC}= 600V$ $I_C= 100A$	$T_{vj}= 25^{\circ}C$		0.39	μs	
			$T_{vj}= 125^{\circ}C$		0.41		
			$T_{vj}= 150^{\circ}C$		0.44		
Fall Time, Inductive load	t_f	$V_{GE}= 15V$ $R_G= 10\Omega$	$T_{vj}= 25^{\circ}C$		0.08	μs	
			$T_{vj}= 125^{\circ}C$		0.10		
			$T_{vj}= 150^{\circ}C$		0.15		
Turn-On Energy	E_{on}		$T_{vj}= 25^{\circ}C$		12.92	mJ	
			$T_{vj}= 125^{\circ}C$		16.08		
			$T_{vj}= 150^{\circ}C$		21.09		
Turn-Off Energy	E_{off}		$T_{vj}= 25^{\circ}C$		5.35	mJ	
			$T_{vj}= 125^{\circ}C$		6.19		
			$T_{vj}= 150^{\circ}C$		7.34		
SC Data	I_{sc}	$V_{CC}= 600V$ $R_G= 20\Omega$ $V_{GE}\leq 15V$ $V_{CEmax}=V_{CE-L_{SCE}}*di/dt$	$t_p\leq 10\mu s$ $T_{vj}= 150^{\circ}C$		400	A	

Diode, Inverter

Description	Symbols	Conditions	Values			Unit
			Min	Typ	Max	
Forward Voltage	V _F	I _F = 100A V _{GE} = 0V	T _{vj} = 25°C	1.49	2.0	V
			T _{vj} = 125°C	1.38		
			T _{vj} = 150°C	1.36		
Recovery Charge	Q _r	I _F = 100A, V _R = 600V -di _F /dt= 1200A/us V _{GE} = -15V	T _{vj} = 25°C	7.90		μC
			T _{vj} = 125°C	16.77		
			T _{vj} = 150°C	22.31		
Reverse Recovery Energy	E _{rec}	I _F = 100A, V _R = 600V -di _F /dt=1200A/us V _{GE} = -15V	T _{vj} = 25°C	3.17		mJ
			T _{vj} = 125°C	6.41		
			T _{vj} = 150°C	8.91		

Thermal resistance

Items	Symbols	Values			Unit
		Min	Typ	Max	
Thermal Resistance, Per IGBT Junction to Case	R _{th(j-c)}			0.20	K/W
Thermal Resistance, Per Diodes Junction to Case	R _{th(j-c)}			0.44	
Thermal Resistance, Case to Heatsink (IGBT+FRD) With 1 W/(m·K) thermal grease	R _{th(c-s)}		0.05		

Module

Description	Symbols	Conditions	Values	Unit
Isolation Test Voltage	V _{ISOL}	RMS, f =50Hz, t= 1min	4.0	KV
Material of Module Base plat			Cu	
Internal Isolation			Al ₂ O ₃	
Creepage Distance	d _{Creep}	Terminal to terminal	10.0	mm
Clearance	d _{Clear}	Terminal to terminal	7.5	mm
Comparative Tracking Index	CTI		200	

Description	Symbols	Conditions	Values			Unit
			Min	Typ	Max	
Stray Inductance Module	L _{sCE}			35.2		nH
Module Lead Resistance , Terminals-Chip	R _{CC'+EE'}	T _C = 25°C, Per switch		4.3		mΩ
Mounting Torque for Module Mounting	M	Screw M5	3.0		6.0	Nm
Weight	G			180		g

NTC Characteristics

Description	Symbols	Conditions	Values			Unit
			Min	Typ	Max	
Rated Resistance	R ₂₅	T _{NTC} =25°C		5.0		KΩ
Deviation of R ₁₀₀	ΔR/R	T _{NTC} =100°C, R ₁₀₀ =493Ω	-5		5	%
Power Dissipation	P ₂₅				20	mW
B-value	B _{25/50}	$R_2=R_{25}\exp[B_{25/50}(1/T_2-1/(298.15K))]$		3388		K
B-value	B _{25/80}	$R_2=R_{25}\exp[B_{25/80}(1/T_2-1/(298.15K))]$		3454		K
B-value	B _{25/100}	$R_2=R_{25}\exp[B_{25/100}(1/T_2-1/(298.15K))]$		3485		K

Output characteristic (typical), IGBT, Inverter

$I_C = f(V_{CE})$

$V_{GE} = 15V$

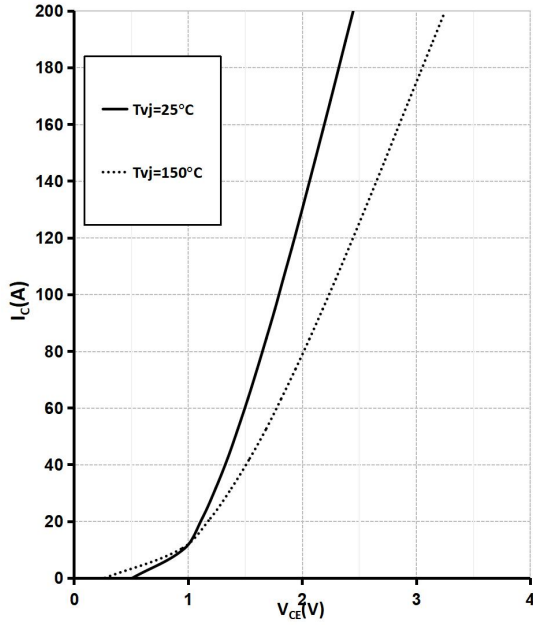

Output characteristic (typical), IGBT, Inverter

$I_C = f(V_{CE})$

$T_{vj} = 150^\circ C$

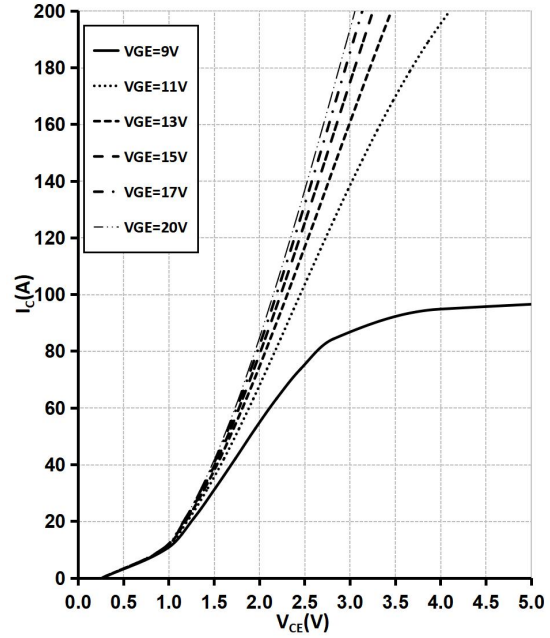

Switching losses (typical), IGBT, Inverter

$E = f(I_C)$

$R_{Goff} = 10\Omega, R_{Gon} = 10\Omega, V_{GE} = \pm 15V, V_{CC} = 600V$

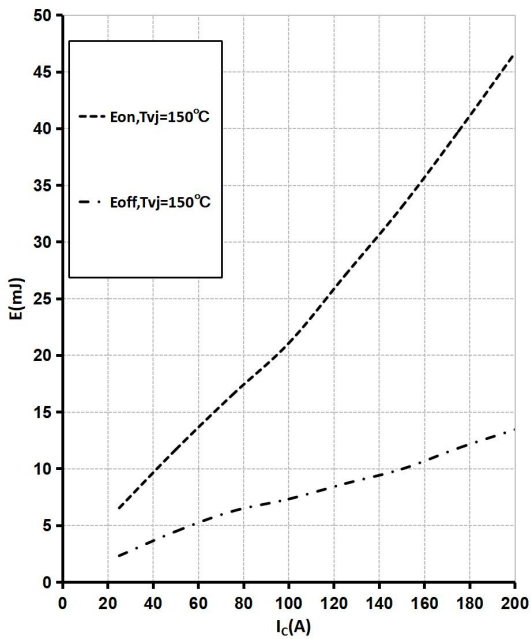

Switching losses (typical), IGBT, Inverter

$E = f(R_G)$

$V_{GE} = 15V, I_C = 100A, V_{CC} = 600V$

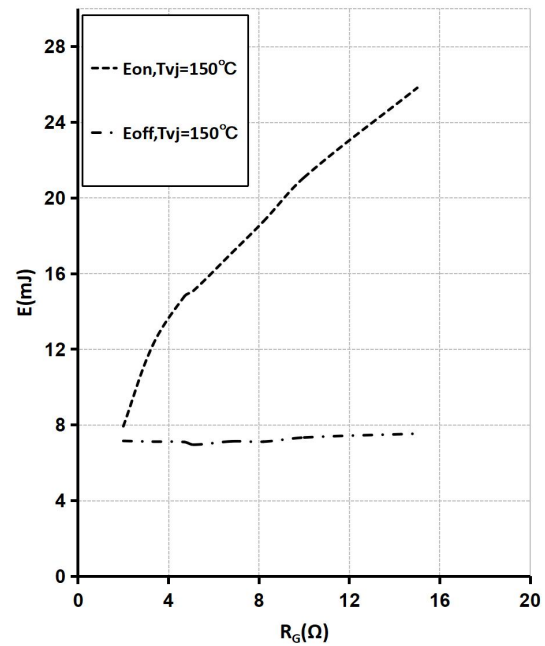

Forward characteristic (typical), Diode, Inverter

$I_F = f(V_F)$

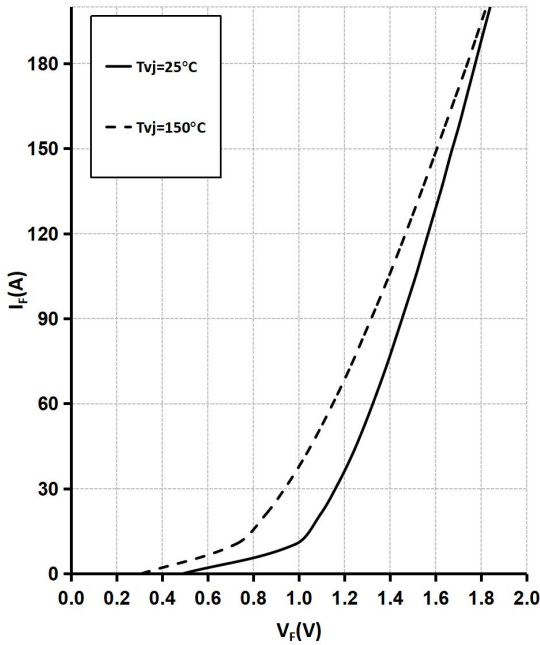

Switching losses (typical), Diode, Inverter

$E_{rec} = f(I_F)$

$R_{Gon} = 10\Omega, V_{CC} = 600V$

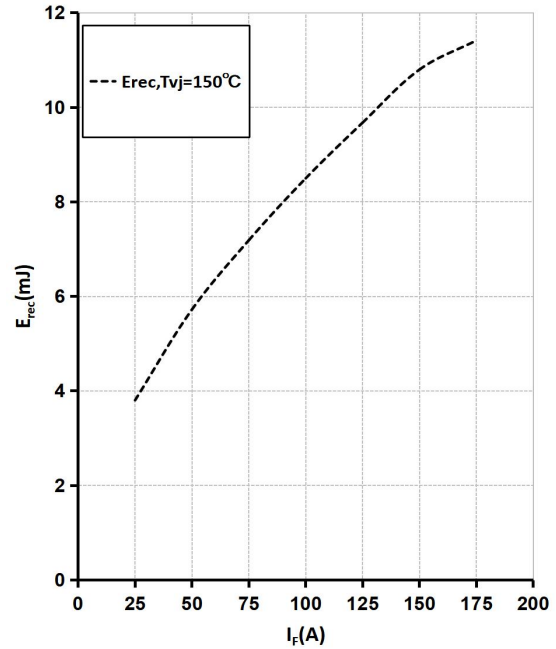

Reverse bias safe operating area (RBSOA), IGBT, Inverter

$I_C = f(V_{CE})$

$R_{Goff} = 10\Omega, V_{GE} = \pm 15V, T_{vj} = 150^\circ C$

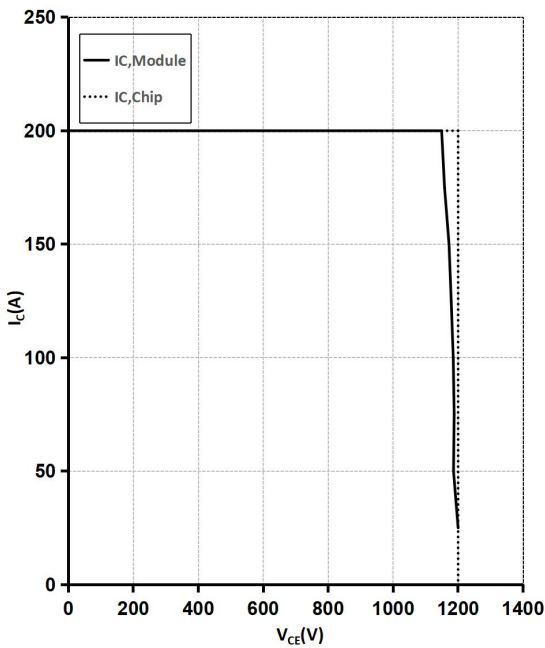

Package Dimension

Dimensions in Millimeters

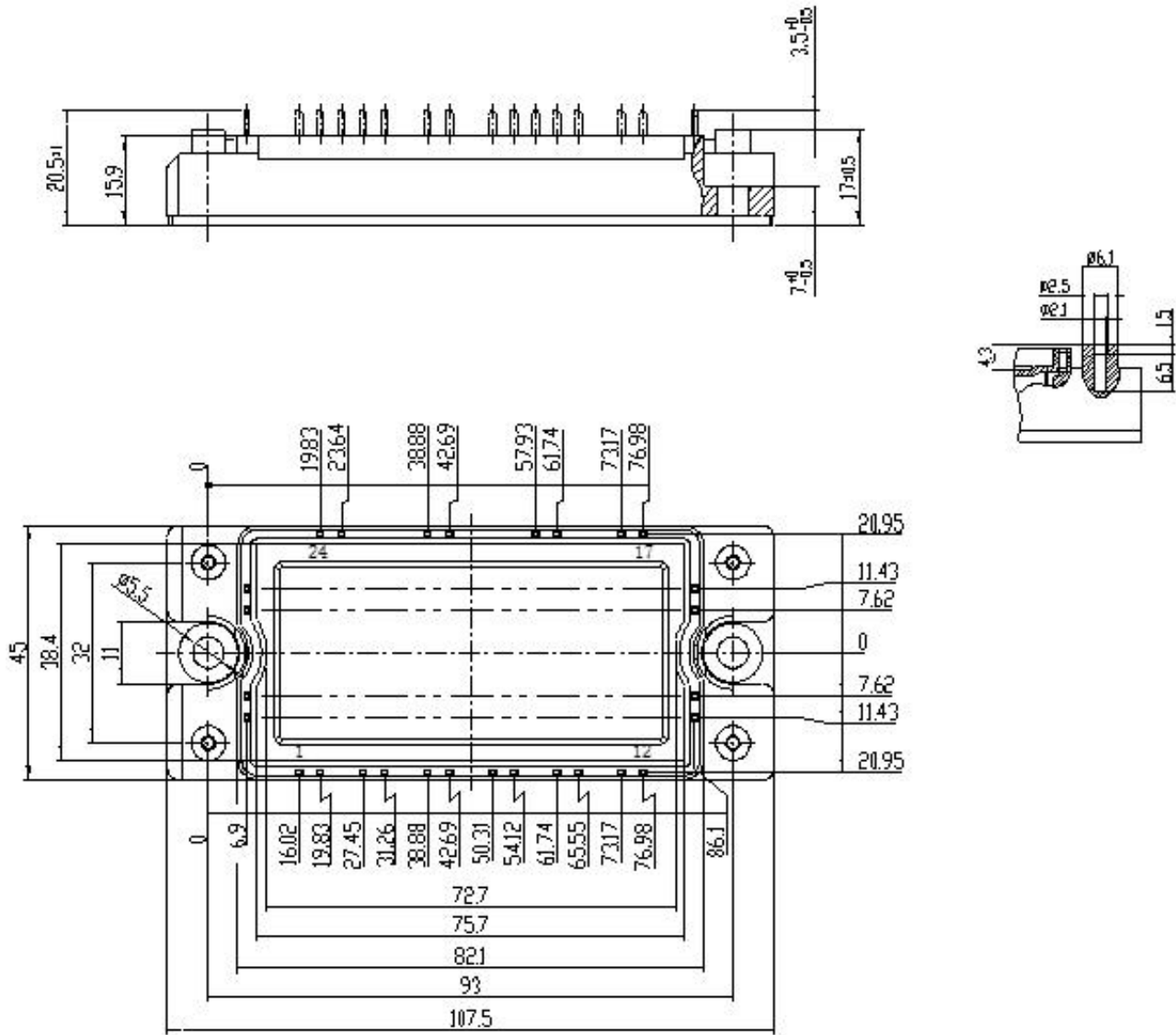

Internal Circuit

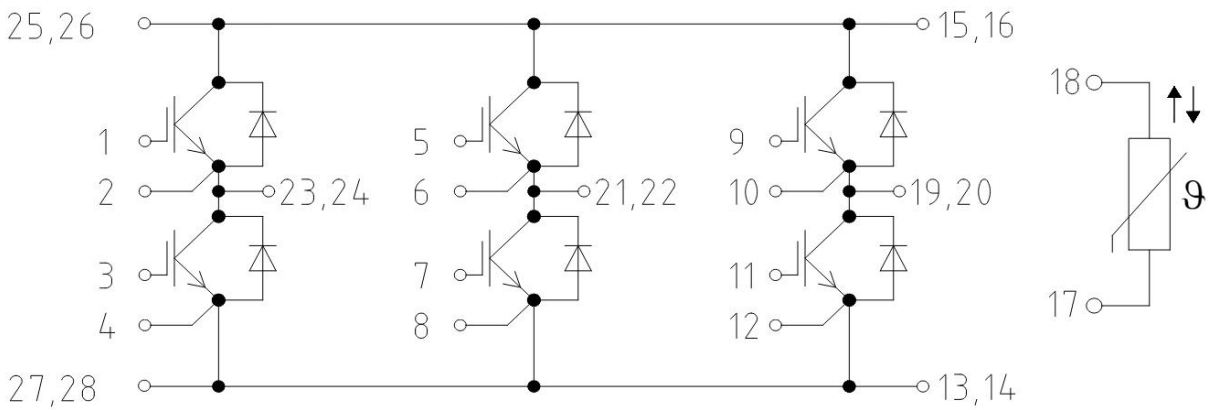

Revision History

Revision	Date	Subjects (major changes since last revision)
0.1	2023-05-23	Preliminary version
1.0	2023-06-19	MP version

The information given herein shall be not regarded as a guarantee of conditions or characteristics . For any examples, hints or any typical values stated herein and/or any information regarding the application of the product, Drvtek hereby disclaims any and all warranties and liabilities of any kind, including without limitation warranties of non-infringement of intellectual property rights of any third party.

In addition, any information given herein is subject to customer's compliance with its obligations stated herein and any applicable legal requirements, norms and standards concerning customer's products and any use of the product of Drvtek in customer's applications.

The data contained herein is exclusively intended for technically trained staff. It is the responsibility of customer to evaluate the suitability of the product for the intended application and the completeness of the product information given herein for such application.

For further information on the product, technology, delivery, conditions and prices please contact Drvtek (www.Drvtek.com).

Warnings

Due to technical requirements products may contain dangerous substances. For information on the types in question please contact Drvtek.

Except as otherwise approved by Drvtek in a written document, Drvtek products may not be used in any applications where a failure of the product or any consequences of the use thereof can reasonably be expected to result in personal injury.